

**2020-2024 Extra Class
FCC Element 4 Question Pool
Effective July 1, 2020**

E1A01 (A) [97.305, 97.307(b)]

Which of the following carrier frequencies is illegal for LSB AFSK emissions on the 17 meter band RTTY and data segment of 18.068 to 18.110 MHz?

A. 18.068 MHz

E1A02 (D) [97.301, 97.305]

When using a transceiver that displays the carrier frequency of phone signals, which of the following displayed frequencies represents the lowest frequency at which a properly adjusted LSB emission will be totally within the band?

D. 3 kHz above the lower band edge

E1A03 (C) [97.305, 97.307(b)]

What is the maximum legal carrier frequency on the 20 meter band for transmitting USB AFSK digital signals having a 1 kHz bandwidth?

C. 14.149 MHz

E1A04 (C) [97.301, 97.305]

With your transceiver displaying the carrier frequency of phone signals, you hear a DX station calling CQ on 3.601 MHz LSB. Is it legal to return the call using lower sideband on the same frequency?

C. No, the sideband will extend beyond the edge of the phone band segment

E1A05 (C) [97.313]

What is the maximum power output permitted on the 60 meter band?

C. 100 watts PEP effective radiated power relative to the gain of a half-wave dipole

E1A06 (B) [97.303(h)(1)]

Where must the carrier frequency of a CW signal be set to comply with FCC rules for 60 meter operation?

B. At the center frequency of the channel

E1A07 (C) [97.313(k)]

What is the maximum power permitted on the 2200 meter band?

C. 1 watt EIRP (Equivalent isotropic radiated power)

E1A08 (B) [97.219]

If a station in a message forwarding system inadvertently forwards a message that is in violation of FCC rules, who is primarily accountable for the rules violation?

B. The control operator of the originating station

E1A09 (A) [97.219]

What action or actions should you take if your digital message forwarding station inadvertently forwards a communication that violates FCC rules?

A. Discontinue forwarding the communication as soon as you become aware of it

E1A10 (A) [97.11]

If an amateur station is installed aboard a ship or aircraft, what condition must be met before the station is operated?

A. Its operation must be approved by the master of the ship or the pilot in command of the aircraft

E1A11 (B) [97.5]

Which of the following describes authorization or licensing required when operating an amateur station aboard a U.S.-registered vessel in international waters?

B. Any FCC-issued amateur license

E1A12 (C)

What special operating frequency restrictions are imposed on slow scan TV transmissions?

C. They are restricted to phone band segments

E1A13 (B) [97.5]

Who must be in physical control of the station apparatus of an amateur station aboard any vessel or craft that is documented or registered in the United States?

B. Any person holding an FCC issued amateur license or who is authorized for alien reciprocal operation

E1A14 (D) [97.313(1)]

Except in some parts of Alaska, what is the maximum power permitted on the 630 meter band?

D. 5 watts EIRP

E1B01 (D) [97.3]

Which of the following constitutes a spurious emission?

D. An emission outside the signal's necessary bandwidth that can be reduced or eliminated without affecting the information transmitted

E1B02 (A) [97.307(f)(2)]

Which of the following is an acceptable bandwidth for Digital Radio Mondiale (DRM) based voice or SSTV digital transmissions made on the HF amateur bands?

A. 3 kHz

E1B03 (A) [97.13]

Within what distance must an amateur station protect an FCC monitoring facility from harmful interference?

A. 1 mile

E1B04 (C) [97.13, 1.1305-1.1319]

What must be done before placing an amateur station within an officially designated wilderness area or wildlife preserve, or an area listed in the National Register of Historic Places?

C. An Environmental Assessment must be submitted to the FCC

E1B05 (C) [97.3]

What is the National Radio Quiet Zone?

C. An area surrounding the National Radio Astronomy Observatory

D. An area in Florida surrounding Cape Canaveral

E1B06 (A) [97.15]

Which of the following additional rules apply if you are installing an amateur station antenna at a site at or near a public use airport?

A. You may have to notify the Federal Aviation Administration and register it with the FCC as required by Part 17 of the FCC rules

E1B07 (C) [97.15]

To what type of regulations does PRB-1 apply?

C. State and local zoning

E1B08 (D) [97.121]

What limitations may the FCC place on an amateur station if its signal causes interference to domestic broadcast reception, assuming that the receivers involved are of good engineering design?

D. The amateur station must avoid transmitting during certain hours on frequencies that cause the interference

E1B09 (C) [97.407]

Which amateur stations may be operated under RACES rules?

C. Any FCC-licensed amateur station certified by the responsible civil defense organization for the area served

E1B10 (A) [97.407]

What frequencies are authorized to an amateur station operating under RACES rules?

A. All amateur service frequencies authorized to the control operator

E1B11 (B) [97.15]

What does PRB-1 require of regulations affecting amateur radio?

B. Reasonable accommodations of amateur radio must be made

E1B12 (A) [97.303(b)]

What must the control operator of a repeater operating in the 70 cm band do if a radiolocation system experiences interference from that repeater?

A. Cease operation or make changes to the repeater to mitigate the interference

E1C01 (D) [97.303]

What is the maximum bandwidth for a data emission on 60 meters?

D. 2.8 kHz

E1C02 (C) [97.117]

Which of the following types of communications may be transmitted to amateur stations in foreign countries?

C. Communications incidental to the purpose of the amateur service and remarks of a personal nature

E1C03 (B) [97.109(d)]

How do the control operator responsibilities of a station under automatic control differ from one under local control?

B. Under automatic control the control operator is not required to be present at the control point

E1C04 (A)

What is meant by IARP?

A. An international amateur radio permit that allows U.S. amateurs to operate in certain countries of the Americas

E1C05 (A) [97.221(c)(1), 97.115(c)]

When may an automatically controlled station originate third party communications?

A. Never

E1C06 (C)

Which of the following is required in order to operate in accordance with CEPT rules in foreign countries where permitted?

C. You must bring a copy of FCC Public Notice DA 16-1048

E1C07 (D) [97.3(a)(8)]

At what level below a signal's mean power level is its bandwidth determined according to FCC rules?

D. 26 dB

E1C08 (B) [97.213]

What is the maximum permissible duration of a remotely controlled station's transmissions if its control link malfunctions?

B. 3 minutes

E1C09 (B) [97.307]

What is the highest modulation index permitted at the highest modulation frequency for angle modulation below 29.0 MHz?

B. 1.0

E1C10 (A) [97.307]

What is the permitted mean power of any spurious emission relative to the mean power of the fundamental emission from a station transmitter or external RF amplifier installed after January 1, 2003 and transmitting on a frequency below 30 MHz?

A. At least 43 dB below

E1C11 (A) [97.5]

Which of the following operating arrangements allows an FCC-licensed U.S. citizen to operate in many European countries, and alien amateurs from many European countries to operate in the U.S.?

A. CEPT agreement

E1C12 (D) [97.305(c)]

On what portion of the 630 meter band are phone emissions permitted?

D. The entire band

E1C13 (C) [97.303(g)]

What notifications must be given before transmitting on the 630 meter or 2200 meter bands?

C. Operators must inform the Utilities Technology Council (UTC) of their call sign and coordinates of the station

E1C14 (B) [97.303(g)]

How long must an operator wait after filing a notification with the Utilities Technology Council (UTC) before operating on the 2200 meter or 630 meter band?

B. Operators may operate after 30 days, providing they have not been told that their station is within 1 km of PLC systems using those frequencies

E1D01 (A) [97.3]

What is the definition of telemetry?

A. One-way transmission of measurements at a distance from the measuring instrument

E1D02 (A) [97.211(b)]

Which of the following may transmit special codes intended to obscure the meaning of messages?

A. Telecommand signals from a space telecommand station

E1D03 (B) [97.3(a)(45)]

What is a space telecommand station?

B. An amateur station that transmits communications to initiate, modify or terminate functions of a space station

E1D04 (A) [97.119(a)]

Which of the following is required in the identification transmissions from a balloon-borne telemetry station?

A. Call sign

E1D05 (D) [97.213(d)]

What must be posted at the station location of a station being operated by telecommand on or within 50 km of the earth's surface?

A. A photocopy of the station license

B. A label with the name, address, and telephone number of the station licensee

C. A label with the name, address, and telephone number of the control operator

D. All these choices are correct

E1D06 (A) [97.215(c)]

What is the maximum permitted transmitter output power when operating a model craft by telecommand?

A. 1 watt

E1D07 (A) [97.207]

Which HF amateur bands have frequencies authorized for space stations?

A. Only the 40, 20, 17, 15, 12, and 10 meter bands

E1D08 (D) [97.207]

Which VHF amateur bands have frequencies authorized for space stations?

D. 2 meters

E1D09 (B) [97.207]

Which UHF amateur bands have frequencies authorized for space stations?

B. 70 cm and 13 cm

E1D10 (B) [97.211]

Which amateur stations are eligible to be telecommand stations of space stations (subject to the privileges of the class of operator license held by the control operator of the station)?

B. Any amateur station so designated by the space station licensee

E1D11 (D) [97.209]

Which amateur stations are eligible to operate as Earth stations?

D. Any amateur station, subject to the privileges of the class of operator license held by the control operator

E1D12 (A) [97.207(e), 97.203(g)]

Which of the following amateur stations may transmit one-way communications?

A. A space station, beacon station, or telecommand station

E1E01 (A) [97.527]

For which types of out-of-pocket expenses do the Part 97 rules state that VEs and VECs may be reimbursed?

A. Preparing, processing, administering, and coordinating an examination for an amateur radio operator license

E1E02 (C) [97.523]

Who does Part 97 task with maintaining the pools of questions for all U.S. amateur license examinations?

C. The VECs

E1E03 (C) [97.521]

What is a Volunteer Examiner Coordinator?

C. An organization that has entered into an agreement with the FCC to coordinate, prepare, and administer amateur operator license examinations

E1E04 (D) [97.509, 97.525]

Which of the following best describes the Volunteer Examiner accreditation process?

D. The procedure by which a VEC confirms that the VE applicant meets FCC requirements to serve as an examiner

E1E05 (B) [97.503]

What is the minimum passing score on all amateur operator license examinations?

B. Minimum passing score of 74%

E1E06 (C) [97.509]

Who is responsible for the proper conduct and necessary supervision during an amateur operator license examination session?

C. Each administering VE

E1E07 (B) [97.509]

What should a VE do if a candidate fails to comply with the examiner's instructions during an amateur operator license examination?

B. Immediately terminate the candidate's examination

E1E08 (C) [97.509]

To which of the following examinees may a VE not administer an examination?

C. Relatives of the VE as listed in the FCC rules

E1E09 (A) [97.509]

What may be the penalty for a VE who fraudulently administers or certifies an examination?

A. Revocation of the VE's amateur station license grant and the suspension of the VE's amateur operator license grant

E1E10 (C) [97.509(h)]

What must the administering VEs do after the administration of a successful examination for an amateur operator license?

C. They must submit the application document to the coordinating VEC according to the coordinating VEC instructions

E1E11 (B) [97.509(m)]

What must the VE team do if an examinee scores a passing grade on all examination elements needed for an upgrade or new license?

B. Three VEs must certify that the examinee is qualified for the license grant and that they have complied with the administering VE requirements

E1E12 (A) [97.509(j)]

What must the VE team do with the application form if the examinee does not pass the exam?

A. Return the application document to the examinee

E1F01 (B) [97.305]

On what frequencies are spread spectrum transmissions permitted?

B. Only on amateur frequencies above 222 MHz

E1F02 (C) [97.107]

What privileges are authorized in the U.S. to persons holding an amateur service license granted by the government of Canada?

C. The operating terms and conditions of the Canadian amateur service license, not to exceed U.S. Amateur Extra Class license privileges

E1F03 (A) [97.315]

Under what circumstances may a dealer sell an external RF power amplifier capable of operation below 144 MHz if it has not been granted FCC certification?

A. It was purchased in used condition from an amateur operator and is sold to another amateur operator for use at that operator's station

E1F04 (A) [97.3]

Which of the following geographic descriptions approximately describes "Line A"?

A. A line roughly parallel to and south of the border between the U.S. and Canada

E1F05 (D) [97.303]

Amateur stations may not transmit in which of the following frequency segments if they are located in the contiguous 48 states and north of Line A?

D. 420 MHz - 430 MHz

E1F06 (A) [1.931]

Under what circumstances might the FCC issue a Special Temporary Authority (STA) to an amateur station?

A. To provide for experimental amateur communications

E1F07 (D) [97.113]

When may an amateur station send a message to a business?

D. When neither the amateur nor his or her employer has a pecuniary interest in the communications

E1F08 (A) [97.113(c)]

Which of the following types of amateur station communications are prohibited?

A. Communications transmitted for hire or material compensation, except as otherwise provided in the rules

E1F09 (D) [97.311]

Which of the following conditions apply when transmitting spread spectrum emissions?

A. A station transmitting SS emission must not cause harmful interference to other stations employing other authorized emissions

B. The transmitting station must be in an area regulated by the FCC or in a country that permits SS emissions

C. The transmission must not be used to obscure the meaning of any communication

D. All these choices are correct

E1F10 (B) [97.201]

Who may be the control operator of an auxiliary station?

B. Only Technician, General, Advanced or Amateur Extra Class operators

E1F11 (D) [97.317]

Which of the following best describes one of the standards that must be met by an external RF power amplifier if it is to qualify for a grant of FCC certification?

D. It must satisfy the FCC's spurious emission standards when operated at the lesser of 1500 watts or its full output power

E2A01 (C)

What is the direction of an ascending pass for an amateur satellite?

C. From south to north

E2A02 (D)

Which of the following occurs when a satellite is using an inverting linear transponder?

A. Doppler shift is reduced because the uplink and downlink shifts are in opposite directions

B. Signal position in the band is reversed

C. Upper sideband on the uplink becomes lower sideband on the downlink, and vice versa

D. All these choices are correct

E2A03 (D)

How is the signal inverted by an inverting linear transponder?

D. The signal is passed through a mixer and the difference rather than the sum is transmitted

E2A04 (B)

What is meant by the term "mode" as applied to an amateur radio satellite?

B. The satellite's uplink and downlink frequency bands

E2A05 (D)

What do the letters in a satellite's mode designator specify?

D. The uplink and downlink frequency ranges

E2A06 (A)

What are Keplerian elements?

A. Parameters that define the orbit of a satellite

E2A07 (D)

Which of the following types of signals can be relayed through a linear transponder?

A. FM and CW

B. SSB and SSTV

C. PSK and packet

D. All these choices are correct

E2A08 (B)

Why should effective radiated power to a satellite that uses a linear transponder be limited?

B. To avoid reducing the downlink power to all other users

E2A09 (A)

What do the terms "L band" and "S band" specify regarding satellite communications?

A. The 23 centimeter and 13 centimeter bands

E2A10 (B)

What type of satellite appears to stay in one position in the sky?

B. Geostationary

E2A11 (B)

What type of antenna can be used to minimize the effects of spin modulation and Faraday rotation?

B. A circularly polarized antenna

E2A12 (C)

What is the purpose of digital store-and-forward functions on an amateur radio satellite?

C. To store digital messages in the satellite for later download by other stations

E2A13 (B)

Which of the following techniques is normally used by low Earth orbiting digital satellites to relay messages around the world?

B. Store-and-forward

E2B01 (A)

How many times per second is a new frame transmitted in a fast-scan (NTSC) television system?

A. 30

E2B02 (C)

How many horizontal lines make up a fast-scan (NTSC) television frame?

C. 525

E2B03 (D)

How is an interlaced scanning pattern generated in a fast-scan (NTSC) television system?

D. By scanning odd numbered lines in one field and even numbered lines in the next

E2B04 (A)

How is color information sent in analog SSTV?

A. Color lines are sent sequentially

E2B05 (C)

Which of the following describes the use of vestigial sideband in analog fast-scan TV transmissions?

C. Vestigial sideband reduces bandwidth while allowing for simple video detector circuitry

E2B06 (A)

What is vestigial sideband modulation?

A. Amplitude modulation in which one complete sideband and a portion of the other are transmitted

E2B07 (B)

What is the name of the signal component that carries color information in NTSC video?

B. Chroma

E2B08 (A)

What technique allows commercial analog TV receivers to be used for fast-scan TV operations on the 70 cm band?

A. Transmitting on channels shared with cable TV

E2B09 (D)

What hardware, other than a receiver with SSB capability and a suitable computer, is needed to decode SSTV using Digital Radio Mondiale (DRM)?

D. No other hardware is needed

E2B10 (A)

What aspect of an analog slow-scan television signal encodes the brightness of the picture?

A. Tone frequency

E2B11 (B)

What is the function of the Vertical Interval Signaling (VIS) code sent as part of an SSTV transmission?

B. To identify the SSTV mode being used

E2B12 (A)

What signals SSTV receiving software to begin a new picture line?

A. Specific tone frequencies

E2C01 (D)

What indicator is required to be used by U.S.-licensed operators when operating a station via remote control and the remote transmitter is located in the U.S.?

D. No additional indicator is required

E2C02 (A)

Which of the following best describes the term "self-spotting" in connection with HF contest operating?

A. The often-prohibited practice of posting one's own call sign and frequency on a spotting network

E2C03 (A)

From which of the following bands is amateur radio contesting generally excluded?

A. 30 meters

E2C04 (B)

Which of the following frequencies are sometimes used for amateur radio mesh networks?

B. Frequencies shared with various unlicensed wireless data services

E2C05 (B)

What is the function of a DX QSL Manager?

B. To handle the receiving and sending of confirmation cards for a DX station

E2C06 (C)

During a VHF/UHF contest, in which band segment would you expect to find the highest level of SSB or CW activity?

C. In the weak signal segment of the band, with most of the activity near the calling frequency

E2C07 (A)

What is the Cabrillo format?

A. A standard for submission of electronic contest logs

E2C08 (B)

Which of the following contacts may be confirmed through the U.S. QSL bureau system?

B. Contacts between a U.S. station and a non-U.S. station

E2C09 (C)

What type of equipment is commonly used to implement an amateur radio mesh network?

C. A wireless router running custom firmware

E2C10 (D)

Why might a DX station state that they are listening on another frequency?

A. Because the DX station may be transmitting on a frequency that is prohibited to some responding stations

B. To separate the calling stations from the DX station

C. To improve operating efficiency by reducing interference

D. All these choices are correct

E2C11 (A)

How should you generally identify your station when attempting to contact a DX station during a contest or in a pileup?

A. Send your full call sign once or twice

E2C12 (C)

What technique do individual nodes use to form a mesh network?

C. Discovery and link establishment protocols

E2D01 (B)

Which of the following digital modes is designed for meteor scatter communications?

B. MSK144

E2D02 (D)

Which of the following is a good technique for making meteor scatter contacts?

A. 15-second timed transmission sequences with stations alternating based on location

B. Use of special digital modes

C. Short transmissions with rapidly repeated call signs and signal reports

D. All these choices are correct

E2D03 (D)

Which of the following digital modes is especially useful for EME communications?

D. JT65

E2D04 (C)

What technology is used to track, in real time, balloons carrying amateur radio transmitters?

C. APRS

E2D05 (B)

What is one advantage of the JT65 mode?

B. The ability to decode signals which have a very low signal-to-noise ratio

E2D06 (A)

Which of the following describes a method of establishing EME contacts?

A. Time synchronous transmissions alternately from each station

E2D07 (C)

What digital protocol is used by APRS?

C. AX.25

E2D08 (A)

What type of packet frame is used to transmit APRS beacon data?

A. Unnumbered Information

E2D09 (A)

What type of modulation is used for JT65 contacts?

A. Multi-tone AFSK

E2D10 (C)

How can an APRS station be used to help support a public service communications activity?

C. An APRS station with a Global Positioning System unit can automatically transmit information to show a mobile station's position during the event

E2D11 (D)

Which of the following data are used by the APRS network to communicate station location?

D. Latitude and longitude

E2E01 (B)

Which of the following types of modulation is common for data emissions below 30 MHz?

B. FSK

E2E02 (A)

What do the letters FEC mean as they relate to digital operation?

A. Forward Error Correction

E2E03 (C)

How is the timing of FT4 contacts organized?

C. Alternating transmissions at 7.5 second intervals

E2E04 (A)

What is indicated when one of the ellipses in an FSK crossed-ellipse display suddenly disappears?

A. Selective fading has occurred

E2E05 (A)

Which of these digital modes does not support keyboard-to-keyboard operation?

A. PACTOR

E2E06 (C)

What is the most common data rate used for HF packet?

C. 300 baud

E2E07 (D)

Which of the following is a possible reason that attempts to initiate contact with a digital station on a clear frequency are unsuccessful?

A. Your transmit frequency is incorrect

B. The protocol version you are using is not supported by the digital station

C. Another station you are unable to hear is using the frequency

D. All these choices are correct

E2E08 (B)

Which of the following HF digital modes can be used to transfer binary files?
B. PACTOR

E2E09 (D)

Which of the following HF digital modes uses variable-length coding for bandwidth efficiency?
D. PSK31

E2E10 (C)

Which of these digital modes has the narrowest bandwidth?
C. PSK31

E2E11 (A)

What is the difference between direct FSK and audio FSK?
A. Direct FSK applies the data signal to the transmitter VFO, while AFSK transmits tones via phone

E2E12 (A)

How do ALE stations establish contact?
A. ALE constantly scans a list of frequencies, activating the radio when the designated call sign is received

E2E13 (D)

Which of these digital modes has the fastest data throughput under clear communication conditions?
D. 300 baud packet

E3A01 (D)

What is the approximate maximum separation measured along the surface of the Earth between two stations communicating by EME?
D. 12,000 miles, if the moon is visible by both stations

E3A02 (B)

What characterizes libration fading of an EME signal?
B. A fluttery irregular fading

E3A03 (A)

When scheduling EME contacts, which of these conditions will generally result in the least path loss?
A. When the moon is at perigee

E3A04 (D)

What do Hepburn maps predict?
D. Probability of tropospheric propagation

E3A05 (C)

Tropospheric propagation of microwave signals often occurs in association with what phenomenon?
C. Warm and cold fronts

E3A06 (B)

What might help to restore contact when DX signals become too weak to copy across an entire HF band a few hours after sunset?
B. Switch to a lower frequency HF band

E3A07 (C)

Atmospheric ducts capable of propagating microwave signals often form over what geographic feature?

C. Bodies of water

E3A08 (A)

When a meteor strikes the Earth's atmosphere, a cylindrical region of free electrons is formed at what layer of the ionosphere?

A. The E layer

E3A09 (C)

Which of the following frequency ranges is most suited for meteor scatter communications?

C. 28 MHz - 148 MHz

E3A10 (B)

Which type of atmospheric structure can create a path for microwave propagation?

B. Temperature inversion

E3A11 (B)

What is a typical range for tropospheric propagation of microwave signals?

B. 100 miles to 300 miles

E3A12 (C)

What is the cause of auroral activity?

C. The interaction in the E layer of charged particles from the Sun with the Earth's magnetic field

E3A13 (A)

Which of these emission modes is best for auroral propagation?

A. CW

E3A14 (B)

What is meant by circularly polarized electromagnetic waves?

B. Waves with a rotating electric field

E3B01 (A)

What is transequatorial propagation?

A. Propagation between two mid-latitude points at approximately the same distance north and south of the magnetic equator

E3B02 (C)

What is the approximate maximum range for signals using transequatorial propagation?

C. 5000 miles

E3B03 (C)

What is the best time of day for transequatorial propagation?

C. Afternoon or early evening

E3B04 (B)

What is meant by the terms "extraordinary" and "ordinary" waves?

B. Independent waves created in the ionosphere that are elliptically polarized

E3B05 (C)

Which amateur bands typically support long-path propagation?

C. 160 meters to 10 meters

E3B06 (B)

Which of the following amateur bands most frequently provides long-path propagation?

B. 20 meters

E3B07 (C)

What happens to linearly polarized radio waves that split into ordinary and extraordinary waves in the ionosphere?

C. They become elliptically polarized

E3B08 (D)

What is the term for the long path opening that exists between two points on the Earth which are simultaneously near sunrise and sunset?

D. Grayline

E3B09 (A)

At what time of year is sporadic E propagation most likely to occur?

A. Around the solstices, especially the summer solstice

E3B10 (A)

Why is chordal hop propagation desirable?

A. The signal experiences less loss compared to multi-hop using Earth as a reflector

E3B11 (D)

At what time of day can sporadic E propagation occur?

D. Any time

E3B12 (B)

What is the primary characteristic of chordal hop propagation?

B. Successive ionospheric refractions without an intermediate reflection from the ground

E3C01 (B)

What does the radio communication term "ray tracing" describe?

B. Modeling a radio wave's path through the ionosphere

E3C02 (A)

What is indicated by a rising A or K index?

A. Increasing disruption of the geomagnetic field

E3C03 (B)

Which of the following signal paths is most likely to experience high levels of absorption when the A index or K index is elevated?

B. Polar

E3C04 (C)

What does the value of B_z (B sub Z) represent?

C. Direction and strength of the interplanetary magnetic field

E3C05 (A)

What orientation of B_z (B sub z) increases the likelihood that incoming particles from the sun will cause disturbed conditions?

A. Southward

E3C06 (A)

By how much does the VHF/UHF radio horizon distance exceed the geometric horizon?

A. By approximately 15 percent of the distance

E3C07 (D)

Which of the following descriptors indicates the greatest solar flare intensity?

D. Class X

E3C08 (A)

What does the space weather term "G5" mean?

A. An extreme geomagnetic storm

E3C09 (B)

How does the intensity of an X3 flare compare to that of an X2 flare?

B. 50 percent greater

E3C10 (B)

What does the 304A solar parameter measure?

B. UV emissions at 304 angstroms, correlated to the solar flux index

E3C11 (C)

What does VOACAP software model?

C. HF propagation

E3C12 (C)

How does the maximum range of ground-wave propagation change when the signal frequency is increased?

C. It decreases

E3C13 (A)

What type of polarization is best for ground-wave propagation?

A. Vertical

E3C14 (D)

Why does the radio-path horizon distance exceed the geometric horizon?

D. Downward bending due to density variations in the atmosphere

E3C15 (B)

What might be indicated by a sudden rise in radio background noise across a large portion of the HF spectrum?

B. A solar flare has occurred

E4A01 (A)

Which of the following limits the highest frequency signal that can be accurately displayed on a digital oscilloscope?

A. Sampling rate of the analog-to-digital converter

E4A02 (B)

Which of the following parameters does a spectrum analyzer display on the vertical and horizontal axes?

B. RF amplitude and frequency

E4A03 (B)

Which of the following test instruments is used to display spurious signals and/or intermodulation distortion products generated by an SSB transmitter?

B. A spectrum analyzer

E4A04 (A)

How is the compensation of an oscilloscope probe typically adjusted?

A. A square wave is displayed and the probe is adjusted until the horizontal portions of the displayed wave are as nearly flat as possible

E4A05 (D)

What is the purpose of the prescaler function on a frequency counter?

D. It divides a higher frequency signal so a low-frequency counter can display the input frequency

E4A06 (A)

What is the effect of aliasing on a digital oscilloscope caused by setting the time base too slow?

A. A false, jittery low-frequency version of the signal is displayed

E4A07 (B)

Which of the following is an advantage of using an antenna analyzer compared to an SWR bridge to measure antenna SWR?

B. Antenna analyzers do not need an external RF source

E4A08 (D)

Which of the following measures SWR?

D. An antenna analyzer

E4A09 (A)

Which of the following is good practice when using an oscilloscope probe?

A. Keep the signal ground connection of the probe as short as possible

B. Never use a high-impedance probe to measure a low-impedance circuit

E4A10 (D)

Which of the following displays multiple digital signal states simultaneously?

D. Logic analyzer

E4A11 (D)

How should an antenna analyzer be connected when measuring antenna resonance and feed point impedance?

D. Connect the antenna feed line directly to the analyzer's connector

E4B01 (B)

Which of the following factors most affects the accuracy of a frequency counter?

B. Time base accuracy

E4B02 (A)

What is the significance of voltmeter sensitivity expressed in ohms per volt?

A. The full scale reading of the voltmeter multiplied by its ohms per volt rating will indicate the input impedance of the voltmeter

E4B03 (C)

Which S parameter is equivalent to forward gain?

C. S₂₁

E4B04 (A)

Which S parameter represents input port return loss or reflection coefficient (equivalent to VSWR)?

A. S₁₁

E4B05 (B)

What three test loads are used to calibrate an RF vector network analyzer?

B. Short circuit, open circuit, and 50 ohms

E4B06 (D)

How much power is being absorbed by the load when a directional power meter connected between a transmitter and a terminating load reads 100 watts forward power and 25 watts reflected power?

D. 75 watts

E4B07 (A)

What do the subscripts of S parameters represent?

A. The port or ports at which measurements are made

E4B08 (C)

Which of the following can be used to measure the Q of a series-tuned circuit?

C. The bandwidth of the circuit's frequency response

E4B09 (D)

What is indicated if the current reading on an RF ammeter placed in series with the antenna feed line of a transmitter increases as the transmitter is tuned to resonance?

D. There is more power going into the antenna

E4B10 (B)

Which of the following methods measures intermodulation distortion in an SSB transmitter?

B. Modulate the transmitter using two AF signals having non-harmonically related frequencies and observe the RF output with a spectrum analyzer

E4B11 (D)

Which of the following can be measured with a vector network analyzer?

- A. Input impedance
- B. Output impedance
- C. Reflection coefficient
- D. All these choices are correct**

E4C01 (D)

What is an effect of excessive phase noise in a receiver's local oscillator?
D. It can combine with strong signals on nearby frequencies to generate interference

E4C02 (A)

Which of the following receiver circuits can be effective in eliminating interference from strong out-of-band signals?

- A. A front-end filter or pre-selector

E4C03 (C)

What is the term for the suppression in an FM receiver of one signal by another stronger signal on the same frequency?

- C. Capture effect

E4C04 (D)

What is the noise figure of a receiver?

- D. The ratio in dB of the noise generated by the receiver to the theoretical minimum noise

E4C05 (B)

What does a receiver noise floor of -174 dBm represent?

- B. The theoretical noise in a 1 Hz bandwidth at the input of a perfect receiver at room temperature

E4C06 (D)

A CW receiver with the AGC off has an equivalent input noise power density of -174 dBm/Hz. What would be the level of an unmodulated carrier input to this receiver that would yield an audio output SNR of 0 dB in a 400 Hz noise bandwidth?

- D. -148 dBm

E4C07 (B)

What does the MDS of a receiver represent?

- B. The minimum discernible signal

E4C08 (D)

An SDR receiver is overloaded when input signals exceed what level?

- D. The reference voltage of the analog-to-digital converter

E4C09 (C)

Which of the following choices is a good reason for selecting a high frequency for the design of the IF in a superheterodyne HF or VHF communications receiver?

- C. Easier for front-end circuitry to eliminate image responses

E4C10 (C)

What is an advantage of having a variety of receiver IF bandwidths from which to select?

C. Receive bandwidth can be set to match the modulation bandwidth, maximizing signal-to-noise ratio and minimizing interference

E4C11 (D)

Why can an attenuator be used to reduce receiver overload on the lower frequency HF bands with little or no impact on signal-to-noise ratio?

D. Atmospheric noise is generally greater than internally generated noise even after attenuation

E4C12 (D)

Which of the following has the largest effect on an SDR receiver's dynamic range?

D. Analog-to-digital converter sample width in bits

E4C13 (C)

How does a narrow-band roofing filter affect receiver performance?

C. It improves dynamic range by attenuating strong signals near the receive frequency

D. All these choices are correct

E4C14 (D)

What transmit frequency might generate an image response signal in a receiver tuned to 14.300 MHz and that uses a 455 kHz IF frequency?

D. 15.210 MHz

E4C15 (D)

What is reciprocal mixing?

D. Local oscillator phase noise mixing with adjacent strong signals to create interference to desired signals

E4D01 (A)

What is meant by the blocking dynamic range of a receiver?

A. The difference in dB between the noise floor and the level of an incoming signal that will cause 1 dB of gain compression

E4D02 (A)

Which of the following describes problems caused by poor dynamic range in a receiver?

A. Spurious signals caused by cross-modulation and desensitization from strong adjacent signals

E4D03 (B)

How can intermodulation interference between two repeaters occur?

B. When the repeaters are in close proximity and the signals mix in the final amplifier of one or both transmitters

E4D04 (B)

Which of the following may reduce or eliminate intermodulation interference in a repeater caused by another transmitter operating in close proximity?

B. A properly terminated circulator at the output of the repeater's transmitter

E4D05 (A)

What transmitter frequencies would cause an intermodulation-product signal in a receiver tuned to 146.70 MHz when a nearby station transmits on 146.52 MHz?
A. 146.34 MHz and 146.61 MHz

E4D06 (D)

What is the term for spurious signals generated by the combination of two or more signals in a non-linear device or circuit?
D. Intermodulation

E4D07 (A)

Which of the following reduces the likelihood of receiver desensitization?
A. Decrease the RF bandwidth of the receiver

E4D08 (C)

What causes intermodulation in an electronic circuit?
C. Nonlinear circuits or devices

E4D09 (C)

What is the purpose of the preselector in a communications receiver?
C. To increase rejection of signals outside the desired band

E4D10 (C)

What does a third-order intercept level of 40 dBm mean with respect to receiver performance?
C. A pair of 40 dBm input signals will theoretically generate a third-order intermodulation product that has the same output amplitude as either of the input signals

E4D11 (A)

Why are odd-order intermodulation products, created within a receiver, of particular interest compared to other products?
A. Odd-order products of two signals in the band of interest are also likely to be within the band

E4D12 (A)

What is the term for the reduction in receiver sensitivity caused by a strong signal near the received frequency?
A. Desensitization

E4E01 (A)

What problem can occur when using an automatic notch filter (ANF) to remove interfering carriers while receiving CW signals?
A. Removal of the CW signal as well as the interfering carrier

E4E02 (D)

Which of the following types of noise can often be reduced with a digital signal processing noise filter?
A. Broadband white noise
B. Ignition noise
C. Power line noise
D. All these choices are correct

E4E03 (B)

Which of the following signals might a receiver noise blanker be able to remove from desired signals?

B. Signals that appear across a wide bandwidth

E4E04 (D)

How can conducted and radiated noise caused by an automobile alternator be suppressed?

D. By connecting the radio's power leads directly to the battery and by installing coaxial capacitors in line with the alternator leads

E4E05 (B)

How can radio frequency interference from an AC motor be suppressed?

B. By installing a brute-force AC-line filter in series with the motor leads

E4E06 (C)

What is one type of electrical interference that might be caused by a nearby personal computer?

C. The appearance of unstable modulated or unmodulated signals at specific frequencies

E4E07 (B)

Which of the following can cause shielded cables to radiate or receive interference?

B. Common-mode currents on the shield and conductors

E4E08 (B)

What current flows equally on all conductors of an unshielded multi-conductor cable?

B. Common-mode current

E4E09 (C)

What undesirable effect can occur when using an IF noise blanker?

C. Nearby signals may appear to be excessively wide even if they meet emission standards

E4E10 (D)

What might be the cause of a loud roaring or buzzing AC line interference that comes and goes at intervals?

A. Arcing contacts in a thermostatically controlled device

B. A defective doorbell or doorbell transformer inside a nearby residence

C. A malfunctioning illuminated advertising display

D. All these choices are correct

E4E11 (B)

What could cause local AM broadcast band signals to combine to generate spurious signals in the MF or HF bands?

B. Nearby corroded metal joints are mixing and re-radiating the broadcast signals

E5A01 (A)

What can cause the voltage across reactances in a series RLC circuit to be higher than the voltage applied to the entire circuit?

A. Resonance

E5A02 (C)

What is resonance in an LC or RLC circuit?

C. The frequency at which the capacitive reactance equals the inductive reactance

E5A03 (D)

What is the magnitude of the impedance of a series RLC circuit at resonance?

D. Approximately equal to circuit resistance

E5A04 (A)

What is the magnitude of the impedance of a parallel RLC circuit at resonance?

A. Approximately equal to circuit resistance

E5A05 (A)

What is the result of increasing the Q of an impedance-matching circuit?

A. Matching bandwidth is decreased

E5A06 (B)

What is the magnitude of the circulating current within the components of a parallel LC circuit at resonance?

B. It is at a maximum

E5A07 (A)

What is the magnitude of the current at the input of a parallel RLC circuit at resonance?

A. Minimum

E5A08 (C)

What is the phase relationship between the current through and the voltage across a series resonant circuit at resonance?

C. The voltage and current are in phase

E5A09 (C)

How is the Q of an RLC parallel resonant circuit calculated?

C. Resistance divided by the reactance of either the inductance or capacitance

E5A10 (A)

How is the Q of an RLC series resonant circuit calculated?

A. Reactance of either the inductance or capacitance divided by the resistance

E5A11 (C)

What is the half-power bandwidth of a resonant circuit that has a resonant frequency of 7.1 MHz and a Q of 150?

C. 47.3 kHz

E5A12 (C)

What is the half-power bandwidth of a resonant circuit that has a resonant frequency of 3.7 MHz and a Q of 118?

C. 31.4 kHz

E5A13 (C)

What is an effect of increasing Q in a series resonant circuit?
C. Internal voltages increase

E5A14 (C)

What is the resonant frequency of an RLC circuit if R is 22 ohms, L is 50 microhenries and C is 40 picofarads?
C. 3.56 MHz

E5A15 (A)

Which of the following increases Q for inductors and capacitors?
A. Lower losses

E5A16 (D)

What is the resonant frequency of an RLC circuit if R is 33 ohms, L is 50 microhenries and C is 10 picofarads?
D. 7.12 MHz

E5B01 (B)

What is the term for the time required for the capacitor in an RC circuit to be charged to 63.2% of the applied voltage or to discharge to 36.8% of its initial voltage?
B. One time constant

E5B02 (D)

What letter is commonly used to represent susceptance?
D. B

E5B03 (B)

How is impedance in polar form converted to an equivalent admittance?
B. Take the reciprocal of the magnitude and change the sign of the angle

E5B04 (D)

What is the time constant of a circuit having two 220-microfarad capacitors and two 1-megohm resistors, all in parallel?
D. 220 seconds

E5B05 (D)

What happens to the magnitude of a pure reactance when it is converted to a susceptance?
D. It becomes the reciprocal

E5B06 (C)

What is susceptance?
C. The imaginary part of admittance

E5B07 (C)

What is the phase angle between the voltage across and the current through a series RLC circuit if X_C is 500 ohms, R is 1 kilohm, and X_L is 250 ohms?
C. 14.0 degrees with the voltage lagging the current

E5B08 (A)

What is the phase angle between the voltage across and the current through a series RLC circuit if X_C is 100 ohms, R is 100 ohms, and X_L is 75 ohms?

A. 14 degrees with the voltage lagging the current

E5B09 (D)

What is the relationship between the AC current through a capacitor and the voltage across a capacitor?

D. Current leads voltage by 90 degrees

E5B10 (A)

What is the relationship between the AC current through an inductor and the voltage across an inductor?

A. Voltage leads current by 90 degrees

E5B11 (B)

What is the phase angle between the voltage across and the current through a series RLC circuit if X_C is 25 ohms, R is 100 ohms, and X_L is 50 ohms?

B. 14 degrees with the voltage leading the current

E5B12 (A)

What is admittance?

A. The inverse of impedance

E5C01 (A)

Which of the following represents capacitive reactance in rectangular notation?

A. $-jX$

E5C02 (C)

How are impedances described in polar coordinates?

C. By phase angle and magnitude

E5C03 (C)

Which of the following represents an inductive reactance in polar coordinates?

C. A positive phase angle

E5C04 (D)

What coordinate system is often used to display the resistive, inductive, and/or capacitive reactance components of impedance?

D. Rectangular coordinates

E5C05 (C)

What is the name of the diagram used to show the phase relationship between impedances at a given frequency?

C. Phasor diagram

E5C06 (B)

What does the impedance $50-j25$ represent?

B. 50 ohms resistance in series with 25 ohms capacitive reactance

E5C07 (D)

Where is the impedance of a pure resistance plotted on rectangular coordinates?

D. On the horizontal axis

E5C08 (D)

What coordinate system is often used to display the phase angle of a circuit containing resistance, inductive and/or capacitive reactance?

D. Polar coordinates

E5C09 (A)

When using rectangular coordinates to graph the impedance of a circuit, what do the axes represent?

A. The X axis represents the resistive component and the Y axis represents the reactive component

E5C10 (B)

Which point on Figure E5-1 best represents the impedance of a series circuit consisting of a 400-ohm resistor and a 38-picofarad capacitor at 14 MHz?

B. Point 4

E5C11 (B)

Which point in Figure E5-1 best represents the impedance of a series circuit consisting of a 300-ohm resistor and an 18-microhenry inductor at 3.505 MHz?

B. Point 3

E5C12 (A)

Which point on Figure E5-1 best represents the impedance of a series circuit consisting of a 300-ohm resistor and a 19-picofarad capacitor at 21.200 MHz?

A. Point 1

E5D01 (A)

What is the result of skin effect?

A. As frequency increases, RF current flows in a thinner layer of the conductor, closer to the surface

E5D02 (B)

Why is it important to keep lead lengths short for components used in circuits for VHF and above?

B. To avoid unwanted inductive reactance

E5D03 (D)

What is microstrip?

D. Precision printed circuit conductors above a ground plane that provide constant impedance interconnects at microwave frequencies

E5D04 (B)

Why are short connections used at microwave frequencies?

B. To reduce phase shift along the connection

E5D05 (C)

What is the power factor of an RL circuit having a 30-degree phase angle between the voltage and the current?

C. 0.866

E5D06 (D)

In what direction is the magnetic field oriented about a conductor in relation to the direction of electron flow?

D. In a circle around the conductor

E5D07 (B)

How many watts are consumed in a circuit having a power factor of 0.71 if the apparent power is 500VA?

B. 355 W

E5D08 (D)

How many watts are consumed in a circuit having a power factor of 0.6 if the input is 200VAC at 5 amperes?

D. 600 watts

E5D09 (B)

What happens to reactive power in an AC circuit that has both ideal inductors and ideal capacitors?

B. It is repeatedly exchanged between the associated magnetic and electric fields, but is not dissipated

E5D10 (A)

How can the true power be determined in an AC circuit where the voltage and current are out of phase?

A. By multiplying the apparent power by the power factor

E5D11 (C)

What is the power factor of an RL circuit having a 60-degree phase angle between the voltage and the current?

C. 0.5

E5D12 (B)

How many watts are consumed in a circuit having a power factor of 0.2 if the input is 100 VAC at 4 amperes?

B. 80 watts

E5D13 (B)

How many watts are consumed in a circuit consisting of a 100-ohm resistor in series with a 100-ohm inductive reactance drawing 1 ampere?

B. 100 watts

E5D14 (A)

What is reactive power?

A. Wattless, nonproductive power

E5D15 (D)

What is the power factor of an RL circuit having a 45-degree phase angle between the voltage and the current?

D. 0.707

E6A01 (C)

In what application is gallium arsenide used as a semiconductor material?
C. In microwave circuits

E6A02 (A)

Which of the following semiconductor materials contains excess free electrons?
A. N-type

E6A03 (C)

Why does a PN-junction diode not conduct current when reverse biased?
C. Holes in P-type material and electrons in the N-type material are separated by the applied voltage, widening the depletion region

E6A04 (C)

What is the name given to an impurity atom that adds holes to a semiconductor crystal structure?
C. Acceptor impurity

E6A05 (C)

How does DC input impedance at the gate of a field-effect transistor compare with the DC input impedance of a bipolar transistor?
C. An FET has higher input impedance

E6A06 (B)

What is the beta of a bipolar junction transistor?
B. The change in collector current with respect to base current

E6A07 (D)

Which of the following indicates that a silicon NPN junction transistor is biased on?
D. Base-to-emitter voltage of approximately 0.6 to 0.7 volts

E6A08 (D)

What term indicates the frequency at which the grounded-base current gain of a transistor has decreased to 0.7 of the gain obtainable at 1 kHz?
D. Alpha cutoff frequency

E6A09 (A)

What is a depletion-mode FET?
A. An FET that exhibits a current flow between source and drain when no gate voltage is applied

E6A10 (B)

In Figure E6-1, what is the schematic symbol for an N-channel dual-gate MOSFET?
B. 4

E6A11 (A)

In Figure E6-1, what is the schematic symbol for a P-channel junction FET?
A. 1

E6A12 (D)

Why do many MOSFET devices have internally connected Zener diodes on the gates?

D. To reduce the chance of static damage to the gate

E6B01 (B)

What is the most useful characteristic of a Zener diode?

B. A constant voltage drop under conditions of varying current

E6B02 (D)

What is an important characteristic of a Schottky diode as compared to an ordinary silicon diode when used as a power supply rectifier?

D. Less forward voltage drop

E6B03 (B)

What type of bias is required for an LED to emit light?

B. Forward bias

E6B04 (A)

What type of semiconductor device is designed for use as a voltage-controlled capacitor?

A. Varactor diode

E6B05 (D)

What characteristic of a PIN diode makes it useful as an RF switch?

D. Low junction capacitance

E6B06 (D)

Which of the following is a common use of a Schottky diode?

D. As a VHF/UHF mixer or detector

E6B07 (B)

What is the failure mechanism when a junction diode fails due to excessive current?

B. Excessive junction temperature

E6B08 (A)

Which of the following is a Schottky barrier diode?

A. Metal-semiconductor junction

E6B09 (C)

What is a common use for point-contact diodes?

E6B10 (B)

In Figure E6-2, what is the schematic symbol for a light-emitting diode?

B. 5

E6B11 (A)

What is used to control the attenuation of RF signals by a PIN diode?

A. Forward DC bias current

E6C01 (A)

What is the function of hysteresis in a comparator?

A. To prevent input noise from causing unstable output signals

E6C02 (B)

What happens when the level of a comparator's input signal crosses the threshold?

B. The comparator changes its output state

E6C03 (A)

What is tri-state logic?

A. Logic devices with 0, 1, and high-impedance output states

E6C04 (C)

Which of the following is an advantage of BiCMOS logic?

C. It has the high input impedance of CMOS and the low output impedance of bipolar transistors

E6C05 (D)

What is an advantage of CMOS logic devices over TTL devices?

D. Lower power consumption

E6C06 (C)

Why do CMOS digital integrated circuits have high immunity to noise on the input signal or power supply?

C. The input switching threshold is about one-half the power supply voltage

E6C07 (B)

What best describes a pull-up or pull-down resistor?

B. A resistor connected to the positive or negative supply line used to establish a voltage when an input or output is an open circuit

E6C08 (B)

In Figure E6-3, what is the schematic symbol for a NAND gate?

B. 2

E6C09 (B)

What is a Programmable Logic Device (PLD)?

B. A programmable collection of logic gates and circuits in a single integrated circuit

E6C10 (D)

In Figure E6-3, what is the schematic symbol for a NOR gate?

D. 4

E6C11 (C)

In Figure E6-3, what is the schematic symbol for the NOT operation (inverter)?

C. 5

E6D01 (A)

Why should core saturation of an impedance matching transformer be avoided?

A. Harmonics and distortion could result

E6D02 (A)

What is the equivalent circuit of a quartz crystal?

A. Motional capacitance, motional inductance, and loss resistance in series, all in parallel with a shunt capacitor representing electrode and stray capacitance

E6D03 (A)

Which of the following is an aspect of the piezoelectric effect?

A. Mechanical deformation of material by the application of a voltage

E6D04 (B)

Which materials are commonly used as a core in an inductor?

B. Ferrite and brass

E6D05 (C)

What is one reason for using ferrite cores rather than powdered iron in an inductor?

C. Ferrite toroids generally require fewer turns to produce a given inductance value

E6D06 (D)

What core material property determines the inductance of an inductor?

D. Permeability

E6D07 (A)

What is current in the primary winding of a transformer called if no load is attached to the secondary?

A. Magnetizing current

E6D08 (B)

What is one reason for using powdered-iron cores rather than ferrite cores in an inductor?

B. Powdered-iron cores generally maintain their characteristics at higher currents

E6D09 (C)

What devices are commonly used as VHF and UHF parasitic suppressors at the input and output terminals of a transistor HF amplifier?

C. Ferrite beads

E6D10 (A)

What is a primary advantage of using a toroidal core instead of a solenoidal core in an inductor?

A. Toroidal cores confine most of the magnetic field within the core material

E6D11 (B)

Which type of core material decreases inductance when inserted into a coil?

B. Brass

E6D12 (C)

What is inductor saturation?

C. The ability of the inductor's core to store magnetic energy has been exceeded

E6D13 (A)

What is the primary cause of inductor self-resonance?

A. Inter-turn capacitance

E6E01 (B)

Why is gallium arsenide (GaAs) useful for semiconductor devices operating at UHF and higher frequencies?

B. Higher electron mobility

E6E02 (A)

Which of the following device packages is a through-hole type?

A. DIP

E6E03 (D)

Which of the following materials is likely to provide the highest frequency of operation when used in MMICs?

D. Gallium nitride

E6E04 (A)

Which is the most common input and output impedance of circuits that use MMICs?

A. 50 ohms

E6E05 (A)

Which of the following noise figure values is typical of a low-noise UHF preamplifier?

A. 2 dB

E6E06 (D)

What characteristics of the MMIC make it a popular choice for VHF through microwave circuits?

D. Controlled gain, low noise figure, and constant input and output impedance over the specified frequency range

E6E07 (D)

What type of transmission line is used for connections to MMICs?

D. Microstrip

E6E08 (A)

How is power supplied to the most common type of MMIC?

A. Through a resistor and/or RF choke connected to the amplifier output lead

E6E09 (D)

Which of the following component package types would be most suitable for use at frequencies above the HF range?

D. Surface mount

E6E10 (D)

What advantage does surface-mount technology offer at RF compared to using through-hole components?

A. Smaller circuit area

B. Shorter circuit-board traces

C. Components have less parasitic inductance and capacitance

D. All these choices are correct

E6E11 (D)

What is a characteristic of DIP packaging used for integrated circuits?

D. A total of two rows of connecting pins placed on opposite sides of the package (Dual In-line Package)

E6E12 (C)

Why are DIP through-hole package ICs not typically used at UHF and higher frequencies?

C. Excessive lead length

E6F01 (C)

What absorbs the energy from light falling on a photovoltaic cell?

C. Electrons

E6F02 (A)

What happens to the conductivity of a photoconductive material when light shines on it?

A. It increases

E6F03 (D)

What is the most common configuration of an optoisolator or optocoupler?

D. An LED and a phototransistor

E6F04 (B)

What is the photovoltaic effect?

B. The conversion of light to electrical energy

E6F05 (A)

Which describes an optical shaft encoder?

A. A device that detects rotation of a control by interrupting a light source with a patterned wheel

E6F06 (A)

Which of these materials is most commonly used to create photoconductive devices?

A. A crystalline semiconductor

E6F07 (B)

What is a solid-state relay?

B. A device that uses semiconductors to implement the functions of an electromechanical relay

E6F08 (C)

Why are optoisolators often used in conjunction with solid-state circuits when switching 120 VAC?

C. Optoisolators provide a very high degree of electrical isolation between a control circuit and the circuit being switched

E6F09 (D)

What is the efficiency of a photovoltaic cell?

D. The relative fraction of light that is converted to current

E6F10 (B)

What is the most common type of photovoltaic cell used for electrical power generation?

B. Silicon

E6F11 (B)

What is the approximate open-circuit voltage produced by a fully illuminated silicon photovoltaic cell?

B. 0.5 V

E7A01 (C)

Which circuit is bistable?

C. A flip-flop

E7A02 (A)

What is the function of a decade counter?

A. It produces one output pulse for every 10 input pulses

E7A03 (B)

Which of the following can divide the frequency of a pulse train by 2?

B. A flip-flop

E7A04 (B)

How many flip-flops are required to divide a signal frequency by 4?

B. 2

E7A05 (D)

Which of the following is a circuit that continuously alternates between two states without an external clock?

D. Astable multivibrator

E7A06 (A)

What is a characteristic of a monostable multivibrator?

A. It switches momentarily to the opposite binary state and then returns to its original state after a set time

E7A07 (D)

What logical operation does a NAND gate perform?

D. It produces logic 0 at its output only when all inputs are logic 1

E7A08 (A)

What logical operation does an OR gate perform?

D. It produces logic 1 at its output if all inputs are logic 0

E7A09 (C)

What logical operation is performed by an exclusive NOR gate?

C. It produces logic 0 at its output if only one input is logic 1

E7A10 (C)

What is a truth table?

C. A list of inputs and corresponding outputs for a digital device

E7A11 (D)

What type of logic defines "1" as a high voltage?

D. Positive Logic

E7B01 (A)

For what portion of the signal cycle does each active element in a push-pull Class AB amplifier conduct?

A. More than 180 degrees but less than 360 degrees

E7B02 (A)

What is a Class D amplifier?

A. A type of amplifier that uses switching technology to achieve high efficiency

E7B03 (A)

Which of the following components form the output of a class D amplifier circuit?

A. A low-pass filter to remove switching signal components

E7B04 (A)

Where on the load line of a Class A common emitter amplifier would bias normally be set?

A. Approximately halfway between saturation and cutoff

E7B05 (C)

What can be done to prevent unwanted oscillations in an RF power amplifier?

C. Install parasitic suppressors and/or neutralize the stage

E7B06 (B)

Which of the following amplifier types reduces even-order harmonics?

B. Push-pull

E7B07 (D)

Which of the following is a likely result when a Class C amplifier is used to amplify a single-sideband phone signal?

D. Signal distortion and excessive bandwidth

E7B08 (C)

How can an RF power amplifier be neutralized?

C. By feeding a 180-degree out-of-phase portion of the output back to the input

E7B09 (D)

Which of the following describes how the loading and tuning capacitors are to be adjusted when tuning a vacuum tube RF power amplifier that employs a Pi-network output circuit?

D. The tuning capacitor is adjusted for minimum plate current, and the loading capacitor is adjusted for maximum permissible plate current

E7B10 (B)

In Figure E7-1, what is the purpose of R1 and R2?

B. Voltage divider bias

E7B11 (D)

In Figure E7-1, what is the purpose of R3?

D. Self bias

E7B12 (C)

What type of amplifier circuit is shown in Figure E7-1?

C. Common emitter

E7B13 (D)

Which of the following describes an emitter follower (or common collector) amplifier?

D. An amplifier with a low impedance output that follows the base input voltage

E7B14 (B)

Why are switching amplifiers more efficient than linear amplifiers?

B. The power transistor is at saturation or cutoff most of the time

E7B15 (C)

What is one way to prevent thermal runaway in a bipolar transistor amplifier?

C. Use a resistor in series with the emitter

E7B16 (A)

What is the effect of intermodulation products in a linear power amplifier?

A. Transmission of spurious signals

E7B17 (A)

Why are odd-order rather than even-order intermodulation distortion products of concern in linear power amplifiers?

A. Because they are relatively close in frequency to the desired signal

E7B18 (C)

What is a characteristic of a grounded-grid amplifier?

C. Low input impedance

E7C01 (D)

How are the capacitors and inductors of a low-pass filter Pi-network arranged between the network's input and output?

D. A capacitor is connected between the input and ground, another capacitor is connected between the output and ground, and an inductor is connected between input and output

E7C02 (C)

Which of the following is a property of a T-network with series capacitors and a parallel shunt inductor?

C. It is a high-pass filter

E7C03 (A)

What advantage does a series-L Pi-L-network have over a series-L Pi-network for impedance matching between the final amplifier of a vacuum-tube transmitter and an antenna?

A. Greater harmonic suppression

E7C04 (C)

How does an impedance-matching circuit transform a complex impedance to a resistive impedance?

C. It cancels the reactive part of the impedance and changes the resistive part to a desired value

E7C05 (D)

Which filter type is described as having ripple in the passband and a sharp cutoff?

D. A Chebyshev filter

E7C06 (C)

What are the distinguishing features of an elliptical filter?

C. Extremely sharp cutoff with one or more notches in the stop band

E7C07 (B)

Which describes a Pi-L-network used for matching a vacuum tube final amplifier to a 50-ohm unbalanced output?

B. A Pi-network with an additional series inductor on the output

E7C08 (A)

Which of the following factors has the greatest effect on the bandwidth and response shape of a crystal ladder filter?

A. The relative frequencies of the individual crystals

E7C09 (D)

What is a crystal lattice filter?

D. A filter with narrow bandwidth and steep skirts made using quartz crystals

E7C10 (B)

Which of the following filters would be the best choice for use in a 2 meter band repeater duplexer?

B. A cavity filter

E7C11 (C)

Which of the following describes a receiving filter's ability to reject signals occupying an adjacent channel?

C. Shape factor

E7C12 (A)

What is one advantage of a Pi-matching network over an L-matching network consisting of a single inductor and a single capacitor?

A. The Q of Pi-networks can be controlled

E7D01 (D)

How does a linear electronic voltage regulator work?

D. The conduction of a control element is varied to maintain a constant output voltage

E7D02 (C)

What is a characteristic of a switching electronic voltage regulator?

C. The controlled device's duty cycle is changed to produce a constant average output voltage

E7D03 (A)

What device is typically used as a stable voltage reference in a linear voltage regulator?

A. A Zener diode

E7D04 (B)

Which of the following types of linear voltage regulator usually make the most efficient use of the primary power source?

B. A series regulator

E7D05 (D)

Which of the following types of linear voltage regulator places a constant load on the unregulated voltage source?

D. A shunt regulator

E7D06 (C)

What is the purpose of Q1 in the circuit shown in Figure E7-2?

C. It controls the current supplied to the load

E7D07 (A)

What is the purpose of C2 in the circuit shown in Figure E7-2?

A. It bypasses rectifier output ripple around D1

E7D08 (C)

What type of circuit is shown in Figure E7-2?

C. Linear voltage regulator

E7D09 (C)

What is the main reason to use a charge controller with a solar power system?

C. Prevention of battery damage due to overcharge

E7D10 (C)

What is the primary reason that a high-frequency switching type high-voltage power supply can be both less expensive and lighter in weight than a conventional power supply?

C. The high frequency inverter design uses much smaller transformers and filter components for an equivalent power output

E7D11 (D)

What is the function of the pass transistor in a linear voltage regulator circuit?

E7D12 (C)

What is the dropout voltage of an analog voltage regulator?

C. Minimum input-to-output voltage required to maintain regulation

E7D13 (C)

What is the equation for calculating power dissipated by a series linear voltage regulator?

C. Voltage difference from input to output multiplied by output current

E7D14 (D)

What is the purpose of connecting equal-value resistors across power supply filter capacitors connected in series?

A. Equalize the voltage across each capacitor

B. Discharge the capacitors when voltage is removed

C. Provide a minimum load on the supply

D. All these choices are correct

E7D15 (D)

What is the purpose of a step-start circuit in a high-voltage power supply?

D. To allow the filter capacitors to charge gradually

E7E01 (B)

Which of the following can be used to generate FM phone emissions?

B. A reactance modulator on the oscillator

E7E02 (D)

What is the function of a reactance modulator?

D. To produce PM or FM signals by using an electrically variable inductance or capacitance

E7E03 (D)

What is a frequency discriminator stage in a FM receiver?

D. A circuit for detecting FM signals

E7E04 (A)

What is one way a single-sideband phone signal can be generated?

A. By using a balanced modulator followed by a filter

E7E05 (D)

What circuit is added to an FM transmitter to boost the higher audio frequencies?

D. A pre-emphasis network

E7E06 (A)

Why is de-emphasis commonly used in FM communications receivers?

A. For compatibility with transmitters using phase modulation

E7E07 (B)

What is meant by the term "baseband" in radio communications?

B. The frequency range occupied by a message signal prior to modulation

E7E08 (C)

What are the principal frequencies that appear at the output of a mixer circuit?

C. The two input frequencies along with their sum and difference frequencies

E7E09 (A)

What occurs when an excessive amount of signal energy reaches a mixer circuit?

A. Spurious mixer products are generated

E7E10 (A)

How does a diode envelope detector function?

A. By rectification and filtering of RF signals

E7E11 (C)

Which type of detector circuit is used for demodulating SSB signals?

C. Product detector

E7F01 (C)

What is meant by direct digital conversion as applied to software defined radios?

C. Incoming RF is digitized by an analog-to-digital converter without being mixed with a local oscillator signal

E7F02 (A)

What kind of digital signal processing audio filter is used to remove unwanted noise from a received SSB signal?

A. An adaptive filter

E7F03 (C)

What type of digital signal processing filter is used to generate an SSB signal?

C. A Hilbert-transform filter

E7F04 (D)

What is a common method of generating an SSB signal using digital signal processing?

D. Signals are combined in quadrature phase relationship

E7F05 (B)

How frequently must an analog signal be sampled by an analog-to-digital converter so that the signal can be accurately reproduced?

B. At least twice the rate of the highest frequency component of the signal

E7F06 (D)

What is the minimum number of bits required for an analog-to-digital converter to sample a signal with a range of 1 volt at a resolution of 1 millivolt?

D. 10 bits

E7F07 (C)

What function is performed by a Fast Fourier Transform?

C. Converting digital signals from the time domain to the frequency domain

E7F08 (B)

What is the function of decimation?

B. Reducing the effective sample rate by removing samples

E7F09 (A)

Why is an anti-aliasing digital filter required in a digital decimator?

A. It removes high-frequency signal components that would otherwise be reproduced as lower frequency components

E7F10 (A)

What aspect of receiver analog-to-digital conversion determines the maximum receive bandwidth of a Direct Digital Conversion SDR?

A. Sample rate

E7F11 (B)

What sets the minimum detectable signal level for a direct-sampling SDR receiver in the absence of atmospheric or thermal noise?

B. Reference voltage level and sample width in bits

E7F12 (A)

Which of the following is an advantage of a Finite Impulse Response (FIR) filter vs an Infinite Impulse Response (IIR) digital filter?

A. FIR filters can delay all frequency components of the signal by the same amount

E7F13 (D)

What is the function of taps in a digital signal processing filter?

- A. To reduce excess signal pressure levels
- D. Provide incremental signal delays for filter algorithms

E7F14 (B)

Which of the following would allow a digital signal processing filter to create a sharper filter response?

- B. More taps

E7G01 (A)

What is the typical output impedance of an op-amp?

- A. Very low

E7G02 (D)

What is ringing in a filter?

- D. Undesired oscillations added to the desired signal

E7G03 (D)

What is the typical input impedance of an op-amp?

- D. Very high

E7G04 (C)

What is meant by the term "op-amp input offset voltage"?

- C. The differential input voltage needed to bring the open loop output voltage to zero

E7G05 (A)

How can unwanted ringing and audio instability be prevented in an op-amp RC audio filter circuit?

- A. Restrict both gain and Q

E7G06 (B)

What is the gain-bandwidth of an operational amplifier?

- B. The frequency at which the open-loop gain of the amplifier equals one

E7G07 (C)

What magnitude of voltage gain can be expected from the circuit in Figure E7-3 when R1 is 10 ohms and RF is 470 ohms?

- C. 47

E7G08 (D)

How does the gain of an ideal operational amplifier vary with frequency?

- D. It does not vary with frequency

E7G09 (D)

What will be the output voltage of the circuit shown in Figure E7-3 if R1 is 1000 ohms, RF is 10,000 ohms, and 0.23 volts DC is applied to the input?

- D. -2.3 volts

E7G10 (C)

What absolute voltage gain can be expected from the circuit in Figure E7-3 when R1 is 1800 ohms and RF is 68 kilohms?

- C. 38

E7G11 (B)

What absolute voltage gain can be expected from the circuit in Figure E7-3 when R_1 is 3300 ohms and R_F is 47 kilohms?

B. 14

E7G12 (A)

What is an operational amplifier?

A. A high-gain, direct-coupled differential amplifier with very high input impedance and very low output impedance

E7H01 (D)

What are three oscillator circuits used in amateur radio equipment?

D. Colpitts, Hartley and Pierce

E7H02 (C)

What is a microphonic?

C. Changes in oscillator frequency due to mechanical vibration

E7H03 (A)

How is positive feedback supplied in a Hartley oscillator?

A. Through a tapped coil

E7H04 (C)

How is positive feedback supplied in a Colpitts oscillator?

C. Through a capacitive divider

E7H05 (D)

How is positive feedback supplied in a Pierce oscillator?

D. Through a quartz crystal

E7H06 (B)

Which of the following oscillator circuits are commonly used in VFOs?

B. Colpitts and Hartley

E7H07 (D)

How can an oscillator's microphonic responses be reduced?

D. Mechanically isolate the oscillator circuitry from its enclosure

E7H08 (A)

Which of the following components can be used to reduce thermal drift in crystal oscillators?

A. NP0 capacitors

E7H09 (A)

What type of frequency synthesizer circuit uses a phase accumulator, lookup table, digital to analog converter, and a low-pass anti-alias filter?

A. A direct digital synthesizer

E7H10 (B)

What information is contained in the lookup table of a direct digital synthesizer (DDS)?

B. Amplitude values that represent the desired waveform

E7H11 (C)

What are the major spectral impurity components of direct digital synthesizers?

C. Spurious signals at discrete frequencies

E7H12 (B)

Which of the following must be done to ensure that a crystal oscillator provides the frequency specified by the crystal manufacturer?

B. Provide the crystal with a specified parallel capacitance

E7H13 (D)

Which of the following is a technique for providing highly accurate and stable oscillators needed for microwave transmission and reception?

A. Use a GPS signal reference

B. Use a rubidium stabilized reference oscillator

C. Use a temperature-controlled high Q dielectric resonator

D. All these choices are correct

E7H14 (C)

What is a phase-locked loop circuit?

C. An electronic servo loop consisting of a phase detector, a low-pass filter, a voltage-controlled oscillator, and a stable reference oscillator

E7H15 (D)

Which of these functions can be performed by a phase-locked loop?

D. Frequency synthesis, FM demodulation

E8A01 (A)

What is the name of the process that shows that a square wave is made up of a sine wave plus all its odd harmonics?

A. Fourier analysis

E8A02 (A)

Which of the following is a type of analog-to-digital conversion?

A. Successive approximation

E8A03 (A)

What type of wave does a Fourier analysis show to be made up of sine waves of a given fundamental frequency plus all its harmonics?

A. A sawtooth wave

E8A04 (B)

What is "dither" with respect to analog-to-digital converters?

B. A small amount of noise added to the input signal to allow more precise representation of a signal over time

E8A05 (D)

What of the following instruments would be the most accurate for measuring the RMS voltage of a complex waveform?

D. A true-RMS calculating meter

E8A06 (A)

What is the approximate ratio of PEP-to-average power in a typical single-sideband phone signal?

A. 2.5 to 1

E8A07 (B)

What determines the PEP-to-average power ratio of a single-sideband phone signal?

B. Speech characteristics

E8A08 (C)

Why would a direct or flash conversion analog-to-digital converter be useful for a software defined radio?

C. Very high speed allows digitizing high frequencies

E8A09 (D)

How many different input levels can be encoded by an analog-to-digital converter with 8-bit resolution?

D. 256

E8A10 (C)

What is the purpose of a low-pass filter used in conjunction with a digital-to-analog converter?

C. Remove harmonics from the output caused by the discrete analog levels generated

E8A11 (A)

Which of the following is a measure of the quality of an analog-to-digital converter?

A. Total harmonic distortion

E8B01 (A)

What is the modulation index of an FM signal?

A. The ratio of frequency deviation to modulating signal frequency

E8B02 (D)

How does the modulation index of a phase-modulated emission vary with RF carrier frequency?

D. It does not depend on the RF carrier frequency

E8B03 (A)

What is the modulation index of an FM-phone signal having a maximum frequency deviation of 3000 Hz either side of the carrier frequency when the modulating frequency is 1000 Hz?

A. 3

E8B04 (B)

What is the modulation index of an FM-phone signal having a maximum carrier deviation of plus or minus 6 kHz when modulated with a 2 kHz modulating frequency?

B. 3

E8B05 (D)

What is the deviation ratio of an FM-phone signal having a maximum frequency swing of plus-or-minus 5 kHz when the maximum modulation frequency is 3 kHz?

D. 1.67

E8B06 (A)

What is the deviation ratio of an FM-phone signal having a maximum frequency swing of plus or minus 7.5 kHz when the maximum modulation frequency is 3.5 kHz?

A. 2.14

E8B07 (A)

Orthogonal Frequency Division Multiplexing is a technique used for which type of amateur communication?

A. High-speed digital modes

E8B08 (D)

What describes Orthogonal Frequency Division Multiplexing?

D. A digital modulation technique using subcarriers at frequencies chosen to avoid intersymbol interference

E8B09 (B)

What is deviation ratio?

B. The ratio of the maximum carrier frequency deviation to the highest audio modulating frequency

E8B10 (B)

What is frequency division multiplexing?

B. Two or more information streams are merged into a baseband, which then modulates the transmitter

E8B11 (B)

What is digital time division multiplexing?

B. Two or more signals are arranged to share discrete time slots of a data transmission

E8C01 (C)

How is Forward Error Correction implemented?

C. By transmitting extra data that may be used to detect and correct transmission errors

E8C02 (C)

What is the definition of symbol rate in a digital transmission?

C. The rate at which the waveform changes to convey information

E8C03 (A)

Why should phase-shifting of a PSK signal be done at the zero crossing of the RF signal?

A. To minimize bandwidth

E8C04 (C)

What technique minimizes the bandwidth of a PSK31 signal?

C. Use of sinusoidal data pulses

E8C05 (C)

What is the approximate bandwidth of a 13-WPM International Morse Code transmission?

C. 52 Hz

E8C06 (C)

What is the bandwidth of a 170-hertz shift, 300-baud ASCII transmission?
C. 0.5 kHz

E8C07 (A)

What is the bandwidth of a 4800-Hz frequency shift, 9600-baud ASCII FM transmission?
A. 15.36 kHz

E8C08 (D)

How does ARQ accomplish error correction?
D. If errors are detected, a retransmission is requested

E8C09 (D)

Which digital code allows only one bit to change between sequential code values?
D. Gray code

E8C10 (C)

How may data rate be increased without increasing bandwidth?
C. Using a more efficient digital code
D. Using forward error correction

E8C11 (A)

What is the relationship between symbol rate and baud?
A. They are the same

E8C12 (C)

What factors affect the bandwidth of a transmitted CW signal?
C. Keying speed and shape factor (rise and fall time)

E8D01 (A)

Why are received spread spectrum signals resistant to interference?
A. Signals not using the spread spectrum algorithm are suppressed in the receiver

E8D02 (B)

What spread spectrum communications technique uses a high-speed binary bit stream to shift the phase of an RF carrier?
B. Direct sequence

E8D03 (D)

How does the spread spectrum technique of frequency hopping work?
D. The frequency of the transmitted signal is changed very rapidly according to a pseudorandom sequence also used by the receiving station

E8D04 (C)

What is the primary effect of extremely short rise or fall time on a CW signal?
C. The generation of key clicks

E8D05 (A)

What is the most common method of reducing key clicks?
A. Increase keying waveform rise and fall times

E8D06 (D)

What is the advantage of including parity bits in ASCII characters?

D. Some types of errors can be detected

E8D07 (D)

What is a common cause of overmodulation of AFSK signals?

D. Excessive transmit audio levels

E8D08 (D)

What parameter evaluates distortion of an AFSK signal caused by excessive input audio levels?

D. Intermodulation Distortion (IMD)

E8D09 (D)

What is considered an acceptable maximum IMD level for an idling PSK signal?

D. -30 dB

E8D10 (B)

What are some of the differences between the Baudot digital code and ASCII?

B. Baudot uses 5 data bits per character, ASCII uses 7 or 8; Baudot uses 2 characters as letters/figures shift codes, ASCII has no letters/figures shift code

E8D11 (C)

What is one advantage of using ASCII code for data communications?

C. It is possible to transmit both upper and lower case text

E9A01 (C)

What is an isotropic antenna?

C. A theoretical, omnidirectional antenna used as a reference for antenna gain

E9A02 (D)

What is the effective radiated power relative to a dipole of a repeater station with 150 watts transmitter power output, 2 dB feed line loss, 2.2 dB duplexer loss, and 7 dBd antenna gain?

D. 286 watts

E9A03 (C)

What is the radiation resistance of an antenna?

C. The value of a resistance that would dissipate the same amount of power as that radiated from an antenna

E9A04 (B)

Which of the following factors affect the feed point impedance of an antenna?

B. Antenna height

E9A05 (D)

What is included in the total resistance of an antenna system?

D. Radiation resistance plus loss resistance

E9A06 (A)

What is the effective radiated power relative to a dipole of a repeater station with 200 watts transmitter power output, 4 dB feed line loss, 3.2 dB duplexer loss, 0.8 dB circulator loss, and 10 dBd antenna gain?

A. 317 watts

E9A07 (B)

What is the effective isotropic radiated power of a repeater station with 200 watts transmitter power output, 2 dB feed line loss, 2.8 dB duplexer loss, 1.2 dB circulator loss, and 7 dBi antenna gain?

B. 252 watts

E9A08 (B)

What is antenna bandwidth?

B. The frequency range over which an antenna satisfies a performance requirement

E9A09 (B)

What is antenna efficiency?

B. Radiation resistance divided by total resistance

E9A10 (A)

Which of the following improves the efficiency of a ground-mounted quarter-wave vertical antenna?

A. Installing a radial system

E9A11 (C)

Which of the following factors determines ground losses for a ground-mounted vertical antenna operating in the 3 MHz to 30 MHz range?

C. Soil conductivity

E9A12 (A)

How much gain does an antenna have compared to a 1/2-wavelength dipole when it has 6 dB gain over an isotropic antenna?

A. 3.85 dB

E9A13 (C)

What term describes station output, taking into account all gains and losses?

C. Effective radiated power

E9B01 (B)

In the antenna radiation pattern shown in Figure E9-1, what is the beamwidth?

B. 50 degrees

E9B02 (B)

In the antenna radiation pattern shown in Figure E9-1, what is the front-to-back ratio?

B. 18 dB

E9B03 (B)

In the antenna radiation pattern shown in Figure E9-1, what is the front-to-side ratio?

B. 14 dB

E9B04 (B)

What is the front-to-back ratio of the radiation pattern shown in Figure E9-2?

B. 28 dB

E9B05 (A)

What type of antenna pattern is shown in Figure E9-2?

A. Elevation

E9B06 (C)

What is the elevation angle of peak response in the antenna radiation pattern shown in Figure E9-2?

C. 7.5 degrees

E9B07 (C)

How does the total amount of radiation emitted by a directional gain antenna compare with the total amount of radiation emitted from a theoretical isotropic antenna, assuming each is driven by the same amount of power?

C. They are the same

E9B08 (D)

What is the far field of an antenna?

D. The region where the shape of the antenna pattern is independent of distance

E9B09 (B)

What type of computer program technique is commonly used for modeling antennas?

B. Method of Moments

E9B10 (A)

What is the principle of a Method of Moments analysis?

A. A wire is modeled as a series of segments, each having a uniform value of current

E9B11 (C)

What is a disadvantage of decreasing the number of wire segments in an antenna model below 10 segments per half-wavelength?

C. The computed feed point impedance may be incorrect

E9C01 (D)

What is the radiation pattern of two $1/4$ -wavelength vertical antennas spaced $1/2$ -wavelength apart and fed 180 degrees out of phase?

D. A figure-8 oriented along the axis of the array

E9C02 (A)

What is the radiation pattern of two $1/4$ wavelength vertical antennas spaced $1/4$ wavelength apart and fed 90 degrees out of phase?

A. Cardioid

E9C03 (C)

What is the radiation pattern of two $1/4$ -wavelength vertical antennas spaced $1/2$ wavelength apart and fed in phase?

C. A Figure-8 broadside to the axis of the array

E9C04 (B)

What happens to the radiation pattern of an unterminated long wire antenna as the wire length is increased?

B. The lobes align more in the direction of the wire

E9C05 (A)

Which of the following is a type of OCFD antenna?

A. A dipole fed approximately 1/3 the way from one end with a 4:1 balun to provide multiband operation

E9C06 (B)

What is the effect of adding a terminating resistor to a rhombic antenna?

B. It changes the radiation pattern from bidirectional to unidirectional

E9C07 (A)

What is the approximate feed point impedance at the center of a two-wire folded dipole antenna?

A. 300 ohms

E9C08 (C)

What is a folded dipole antenna?

C. A half-wave dipole with an additional parallel wire connecting its two ends

E9C09 (A)

Which of the following describes a G5RV antenna?

A. A multi-band dipole antenna fed with coax and a balun through a selected length of open wire transmission line

E9C10 (B)

Which of the following describes a Zepp antenna?

B. An end-fed dipole antenna

E9C11 (D)

How is the far-field elevation pattern of a vertically polarized antenna affected by being mounted over seawater versus soil?

D. The low-angle radiation increases

E9C12 (C)

Which of the following describes an Extended Double Zepp antenna?

C. A center-fed 1.25-wavelength antenna (two 5/8-wave elements in phase)

E9C13 (B)

How does the radiation pattern of a horizontally polarized 3-element beam antenna vary with increasing height above ground?

B. The takeoff angle of the lowest elevation lobe decreases

E9C14 (B)

How does the performance of a horizontally polarized antenna mounted on the side of a hill compare with the same antenna mounted on flat ground?

B. The main lobe takeoff angle decreases in the downhill direction

E9D01 (D)

How much does the gain of an ideal parabolic dish antenna change when the operating frequency is doubled?

D. 6 dB

E9D02 (C)

How can linearly polarized Yagi antennas be used to produce circular polarization?

C. Arrange two Yagis perpendicular to each other with the driven elements at the same point on the boom fed 90 degrees out of phase

E9D03 (A)

Where should a high Q loading coil be placed to minimize losses in a shortened vertical antenna?

A. Near the center of the vertical radiator

E9D04 (C)

Why should an HF mobile antenna loading coil have a high ratio of reactance to resistance?

C. To minimize losses

E9D05 (B)

What usually occurs if a Yagi antenna is designed solely for maximum forward gain?

B. The front-to-back ratio decreases

E9D06 (B)

What happens to the SWR bandwidth when one or more loading coils are used to resonate an electrically short antenna?

B. It is decreased

E9D07 (D)

What is an advantage of using top loading in a shortened HF vertical antenna?

D. Improved radiation efficiency

E9D08 (B)

What happens as the Q of an antenna increases?

B. SWR bandwidth decreases

E9D09 (D)

What is the function of a loading coil used as part of an HF mobile antenna?

D. To cancel capacitive reactance

E9D10 (B)

What happens to feed-point impedance at the base of a fixed length HF mobile antenna when operated below its resonant frequency?

B. The radiation resistance decreases and the capacitive reactance increases

E9D11 (B)

Which of the following conductors would be best for minimizing losses in a station's RF ground system?

B. Wide flat copper strap

E9D12 (C)

Which of the following would provide the best RF ground for your station?
C. An electrically short connection to 3 or 4 interconnected ground rods driven into the Earth

E9E01 (B)

What system matches a higher-impedance transmission line to a lower-impedance antenna by connecting the line to the driven element in two places spaced a fraction of a wavelength each side of element center?
B. The delta matching system

E9E02 (A)

What is the name of an antenna matching system that matches an unbalanced feed line to an antenna by feeding the driven element both at the center of the element and at a fraction of a wavelength to one side of center?
A. The gamma match

E9E03 (D)

What is the name of the matching system that uses a section of transmission line connected in parallel with the feed line at or near the feed point?
D. The stub match

E9E04 (B)

What is the purpose of the series capacitor in a gamma-type antenna matching network?
B. To cancel the inductive reactance of the matching network

E9E05 (A)

How must an antenna's driven element be tuned to use a hairpin matching system?
A. The driven element reactance must be capacitive

E9E06 (C)

Which of these feed line impedances would be suitable for constructing a quarter-wave Q-section for matching a 100-ohm loop to 50-ohm feed line?
C. 75 ohms

E9E07 (B)

What parameter describes the interactions at the load end of a mismatched transmission line?
B. Reflection coefficient

E9E08 (C)

What is a use for a Wilkinson divider?
C. It is used to divide power equally between two 50-ohm loads while maintaining 50-ohm input impedance

E9E09 (C)

Which of the following is used to shunt-feed a grounded tower at its base?
C. Gamma match

E9E10 (C)

Which of these choices is an effective way to match an antenna with a 100-ohm feed point impedance to a 50-ohm coaxial cable feed line?

C. Insert a 1/4-wavelength piece of 75-ohm coaxial cable transmission line in series between the antenna terminals and the 50-ohm feed cable

E9E11 (A)

What is the primary purpose of phasing lines when used with an antenna having multiple driven elements?

A. It ensures that each driven element operates in concert with the others to create the desired antenna pattern

E9F01 (D)

What is the velocity factor of a transmission line?

D. The velocity of the wave in the transmission line divided by the velocity of light in a vacuum

E9F02 (C)

Which of the following has the biggest effect on the velocity factor of a transmission line?

C. Dielectric materials used in the line

E9F03 (D)

Why is the physical length of a coaxial cable transmission line shorter than its electrical length?

D. Electrical signals move more slowly in a coaxial cable than in air

E9F04 (B)

What impedance does a 1/2-wavelength transmission line present to a generator when the line is shorted at the far end?

B. Very low impedance

E9F05 (D)

What is the approximate physical length of a solid polyethylene dielectric coaxial transmission line that is electrically 1/4 wavelength long at 14.1 MHz?

D. 3.5 meters

E9F06 (C)

What is the approximate physical length of an air-insulated, parallel conductor transmission line that is electrically 1/2 wavelength long at 14.10 MHz?

C. 10.6 meters

E9F07 (A)

How does ladder line compare to small-diameter coaxial cable such as RG-58 at 50 MHz?

A. Lower loss

E9F08 (D)

Which of the following is a significant difference between foam dielectric coaxial cable and solid dielectric cable, assuming all other parameters are the same?

- A. Foam dielectric has lower safe operating voltage limits
- B. Foam dielectric has lower loss per unit of length
- C. Foam dielectric has higher velocity factor

D. All these choices are correct

E9F09 (B)

What is the approximate physical length of a foam polyethylene dielectric coaxial transmission line that is electrically $1/4$ wavelength long at 7.2 MHz?

- B. 8.3 meters

E9F10 (C)

What impedance does a $1/8$ -wavelength transmission line present to a generator when the line is shorted at the far end?

- C. An inductive reactance

E9F11 (C)

What impedance does a $1/8$ -wavelength transmission line present to a generator when the line is open at the far end?

- C. A capacitive reactance

E9F12 (D)

What impedance does a $1/4$ -wavelength transmission line present to a generator when the line is open at the far end?

- D. Very low impedance

E9F13 (A)

What impedance does a $1/4$ -wavelength transmission line present to a generator when the line is shorted at the far end?

- A. Very high impedance

E9G01 (A)

Which of the following can be calculated using a Smith chart?

- A. Impedance along transmission lines

E9G02 (B)

What type of coordinate system is used in a Smith chart?

- B. Resistance circles and reactance arcs

E9G03 (C)

Which of the following is often determined using a Smith chart?

- C. Impedance and SWR values in transmission lines

E9G04 (C)

What are the two families of circles and arcs that make up a Smith chart?

- C. Resistance and reactance

E9G05 (A)

Which of the following is a common use for a Smith chart?

- A. Determine the length and position of an impedance matching stub

E9G06 (B)

On the Smith chart shown in Figure E9-3, what is the name for the large outer circle on which the reactance arcs terminate?

B. Reactance axis

E9G07 (D)

On the Smith chart shown in Figure E9-3, what is the only straight line shown?

D. The resistance axis

E9G08 (C)

What is the process of normalization with regard to a Smith chart?

C. Reassigning impedance values with regard to the prime center

E9G09 (A)

What third family of circles is often added to a Smith chart during the process of solving problems?

A. Standing wave ratio circles

E9G10 (D)

What do the arcs on a Smith chart represent?

D. Points with constant reactance

E9G11 (B)

How are the wavelength scales on a Smith chart calibrated?

B. In fractions of transmission line electrical wavelength

E9H01 (D)

When constructing a Beverage antenna, which of the following factors should be included in the design to achieve good performance at the desired frequency?

D. It should be one or more wavelengths long

E9H02 (A)

Which is generally true for low band (160 meter and 80 meter) receiving antennas?

A. Atmospheric noise is so high that gain over a dipole is not important

E9H03 (D)

What is Receiving Directivity Factor (RDF)?

D. Forward gain compared to average gain over the entire hemisphere

E9H04 (B)

What is an advantage of placing a grounded electrostatic shield around a small loop direction-finding antenna?

B. It eliminates unbalanced capacitive coupling to the surroundings, improving the nulls

E9H05 (A)

What is the main drawback of a small wire-loop antenna for direction finding?

A. It has a bidirectional pattern

E9H06 (C)

What is the triangulation method of direction finding?

C. Antenna headings from several different receiving locations are used to locate the signal source

E9H07 (D)

Why is RF attenuation used when direction-finding?

D. To prevent receiver overload which reduces pattern nulls

E9H08 (A)

What is the function of a sense antenna?

A. It modifies the pattern of a DF antenna array to provide a null in one direction

E9H09 (B)

What is a Pennant antenna?

B. A small, vertically oriented receiving antenna consisting of a triangular loop terminated in approximately 900 ohms

E9H10 (D)

How can the output voltage of a multiple-turn receiving loop antenna be increased?

D. By increasing the number of turns and/or the area

E9H11 (B)

What feature of a cardioid pattern antenna makes it useful for direction finding?

B. A very sharp single null

E0A01 (B)

What is the primary function of an external earth connection or ground rod?

B. Lightning protection

E0A02 (B)

When evaluating RF exposure levels from your station at a neighbor's home, what must you do?

B. Ensure signals from your station are less than the uncontrolled Maximum Permitted Exposure (MPE) limits

E0A03 (C)

Over what range of frequencies are the FCC human body RF exposure limits most restrictive?

C. 30 to 300 MHz

E0A04 (C)

When evaluating a site with multiple transmitters operating at the same time, the operators and licensees of which transmitters are responsible for mitigating over-exposure situations?

C. Each transmitter that produces 5 percent or more of its MPE limit in areas where the total MPE limit is exceeded.

E0A05 (B)

What is one of the potential hazards of operating in the amateur radio microwave bands?

B. The high gain antennas commonly used can result in high exposure levels

E0A06 (D)

Why are there separate electric (E) and magnetic (H) field MPE limits?

- A. The body reacts to electromagnetic radiation from both the E and H fields
- B. Ground reflections and scattering make the field strength vary with location
- C. E field and H field radiation intensity peaks can occur at different locations

D. All these choices are correct

E0A07 (B)

How many dangerous levels of carbon monoxide from an emergency generator be detected?

- B. Only with a carbon monoxide detector

E0A08 (C)

What does SAR measure?

- C. The rate at which RF energy is absorbed by the body

E0A09 (C)

Which insulating material commonly used as a thermal conductor for some types of electronic devices is extremely toxic if broken or crushed and the particles are accidentally inhaled?

- C. Beryllium Oxide

E0A10 (A)

What toxic material may be present in some electronic components such as high voltage capacitors and transformers?

- A. Polychlorinated biphenyls

E0A11 (C)

Which of the following injuries can result from using high-power UHF or microwave transmitters?

- C. Localized heating of the body from RF exposure in excess of the MPE limits

NOTE: The graphics are required for certain questions in sections E5, E6, E7, and E9 are included on the following pages.

Figure E5-1

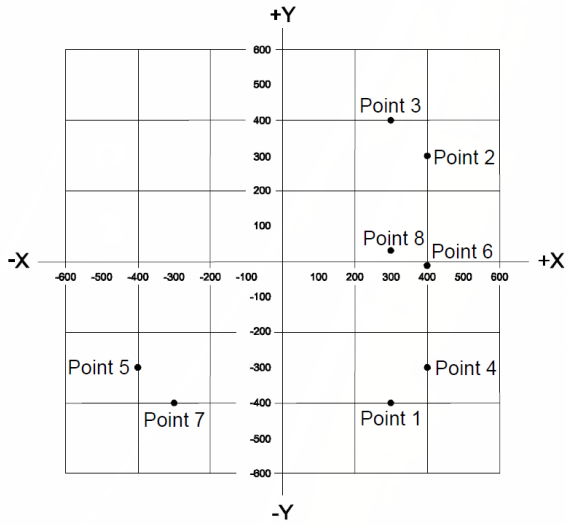

Figure E6-1

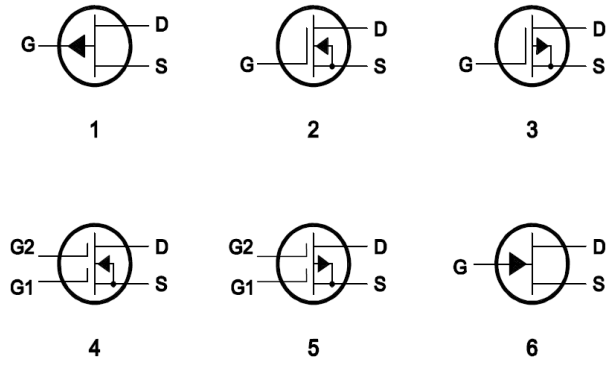

Figure E6-2

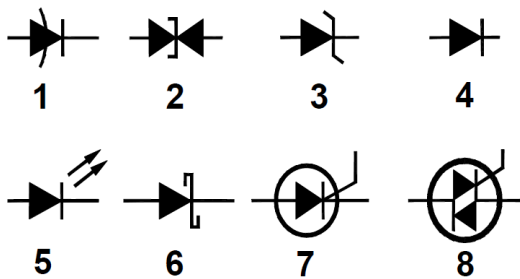

Figure E6-3

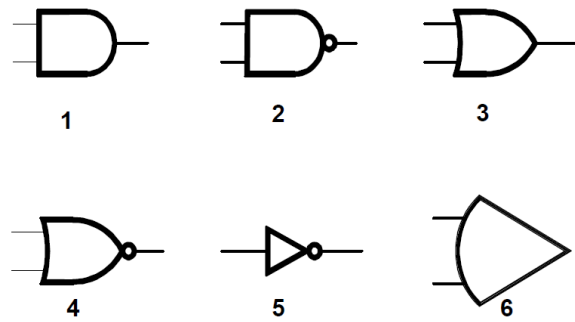

Figure E7-1

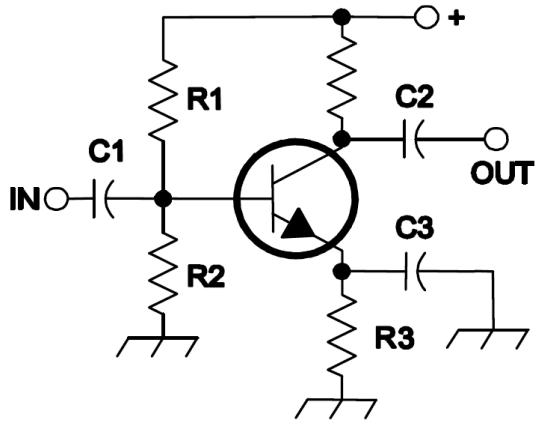

Figure E7-2

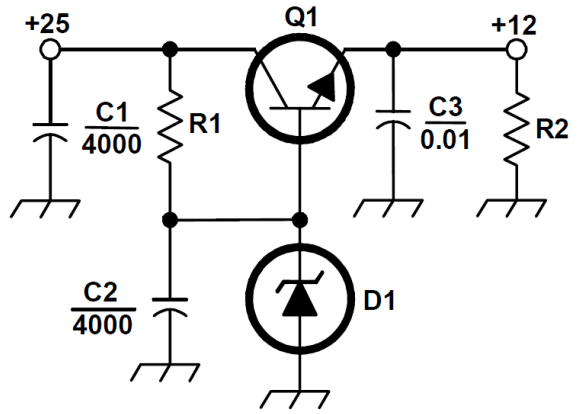

Figure E7-3

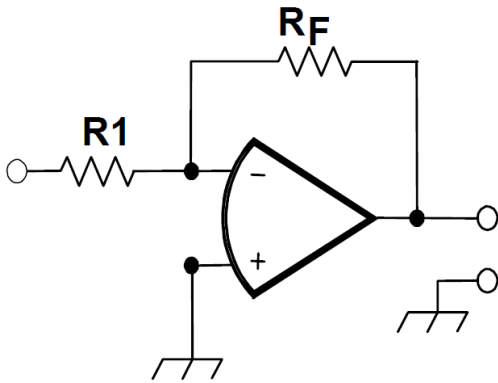

Figure E9-1

